

## Amphibian

*Amphibian* pumps are waterproof, water-cooled pressure pumps with internal controls that start and stop water flow in response to demand without the need for external pressure switches or pump controllers. Unlike other fully automatic pumps, they can be exposed to the elements without rain or sun protection, enclosed in underground vaults without ventilation, or fully submerged.

Sophisticated electronic circuitry provides automatic dry-run shutdown when there is no pressure or flow as well as automatic anti-lock shaft rotation when the pump is inactive for an extended period. Standard features include oil-lubricated ceramic/carbon seals, 48 foot power cords, and calibrated external check valves.

The Amphibian-J125 is a 1-1/4 hp self-priming jet pump with a stainless-steel motor housing, technopolymer suction and control ends, and a noryl impeller. The Amphibian-M125 is a 1-1/4 hp high-flow multi-stage pump with a 100% stainless-steel shell, brass bearing supports, and a stainless-steel impeller. Amphibian-M pumps are not self-priming and are not recommended for use where the water level is below the pump.



J125



M125

### HYDRAULIC PERFORMANCE

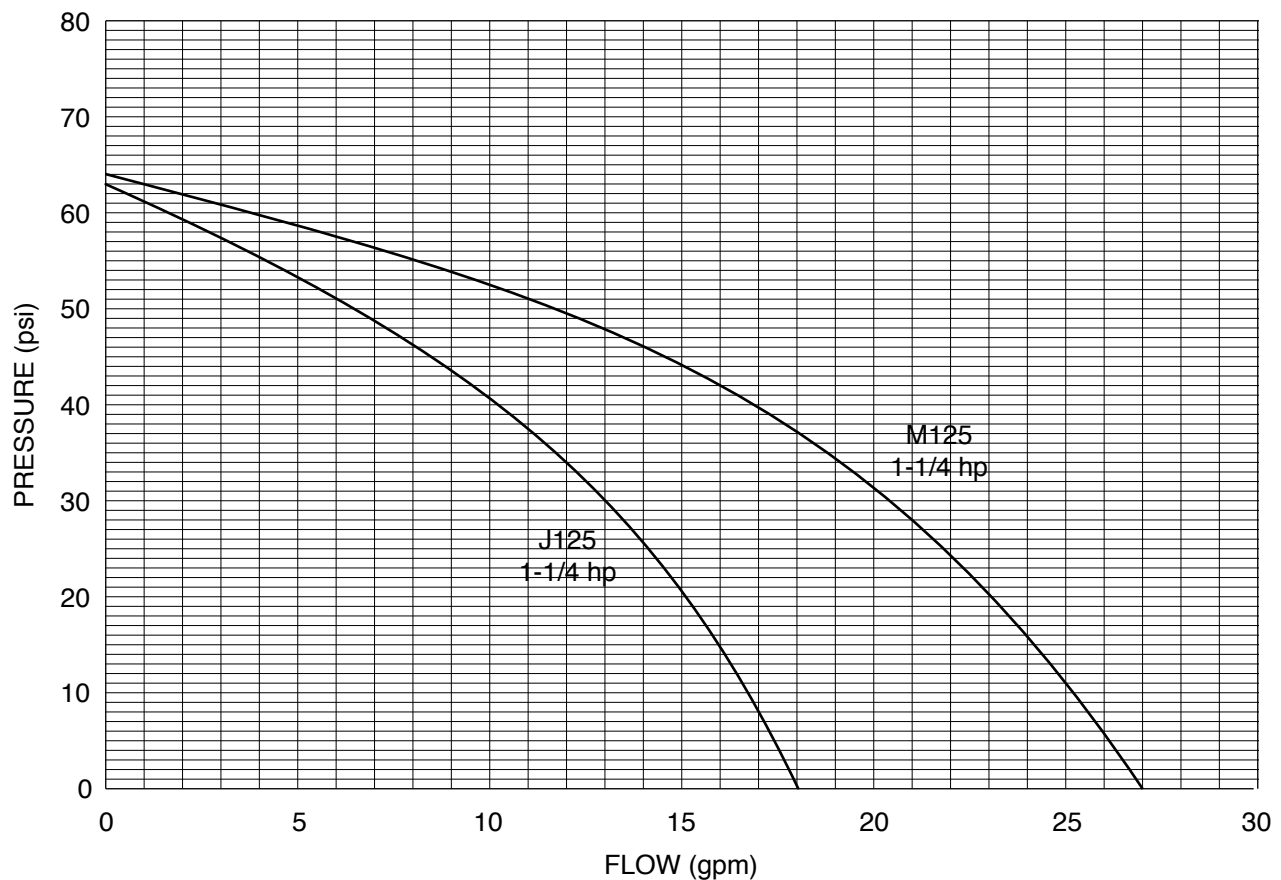

## PHYSICAL AND ELECTRICAL CHARACTERISTICS

Model	Power	Voltage	Current	Inlet	Outlet	LxWxH	Weight
Amphibian-J125	1.25 hp	120v-1Ø	14 a	1" fpt	1-1/4" fpt	18x8x9	29 lb
Amphibian-M125	1.25 hp	240v-1Ø	7 a	1" fpt	1-1/4" fpt	18x8x9	38 lb

Amphibian-J125

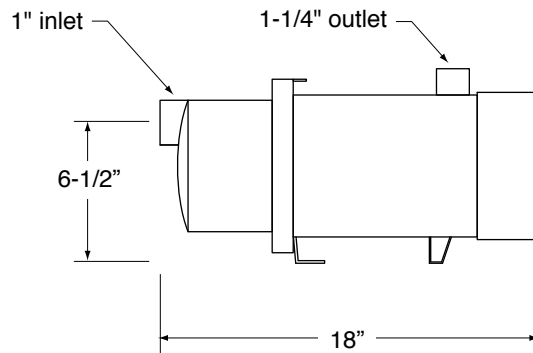
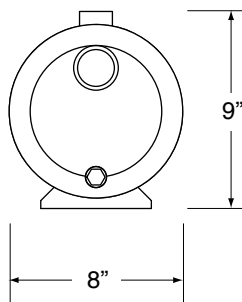
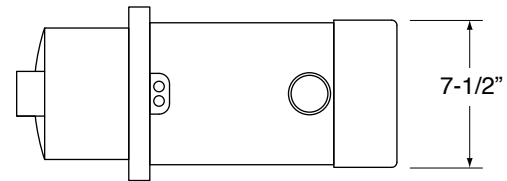

Amphibian-M125

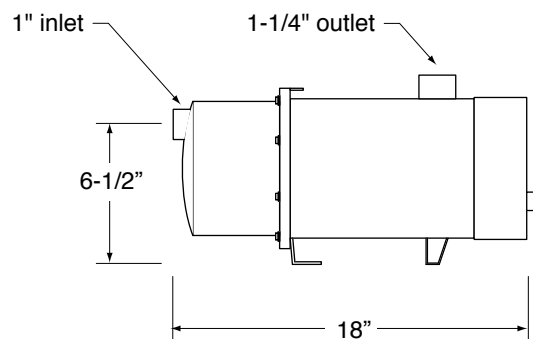
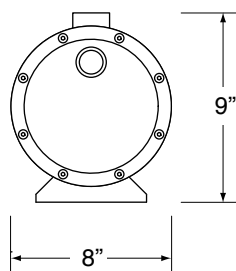
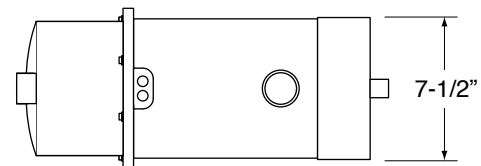

## INSTALLATION DETAILS

Amphibian pumps are supplied as complete kits that include all of the prefilters, valves, connecting hoses, and fittings required for quick and reliable installation. A heavy-duty 29 x 42 x 24" plastic utility enclosure is available for underground installation. Water distribution pipe (typically rigid PVC or flexible polyethylene, not included) should be at least 1" for the Amphibian-J125 and 1-1/4" for the higher flow Amphibian-M125.

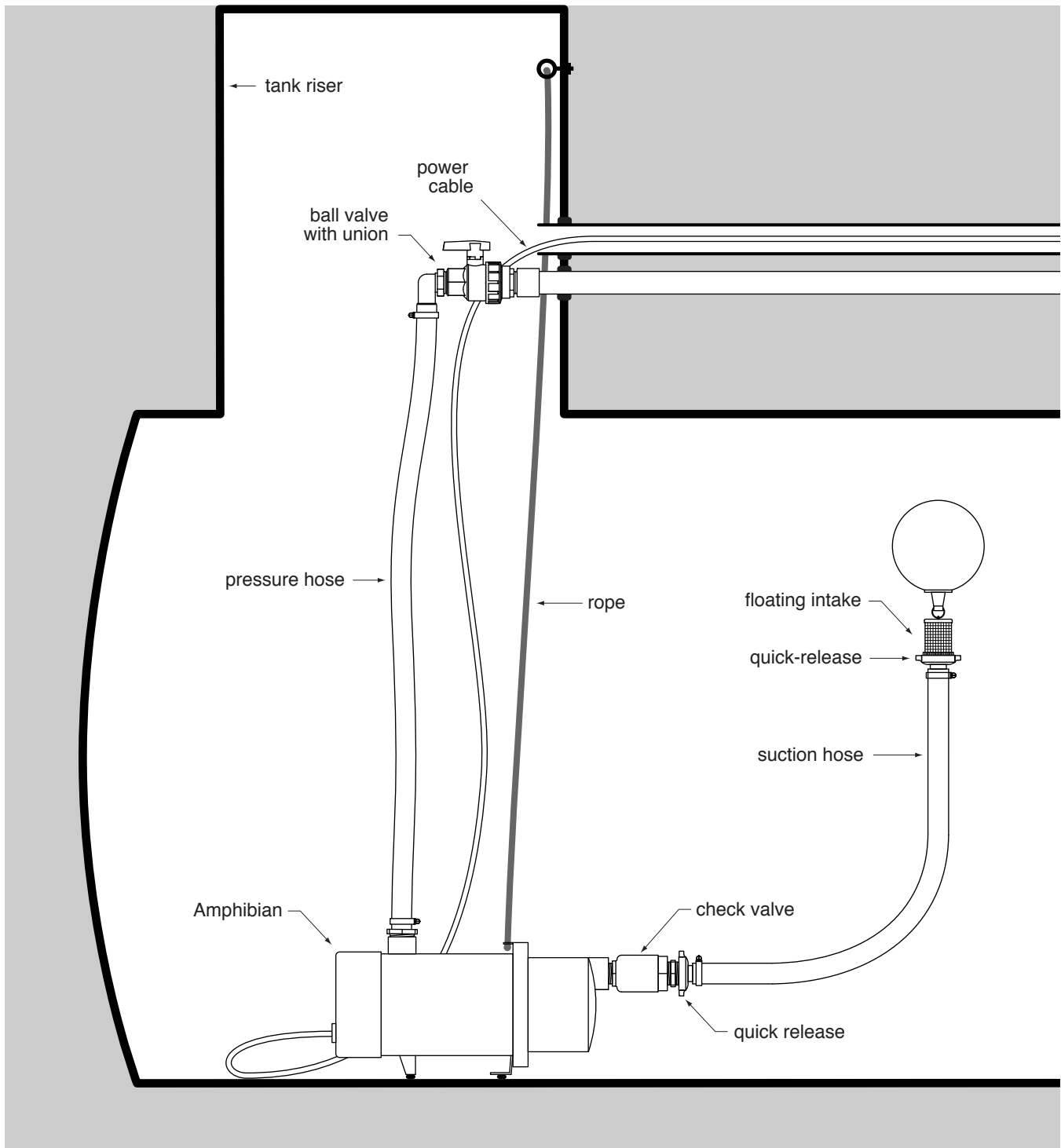

submerged Amphibian system with screened floating intake system installed in underground tank

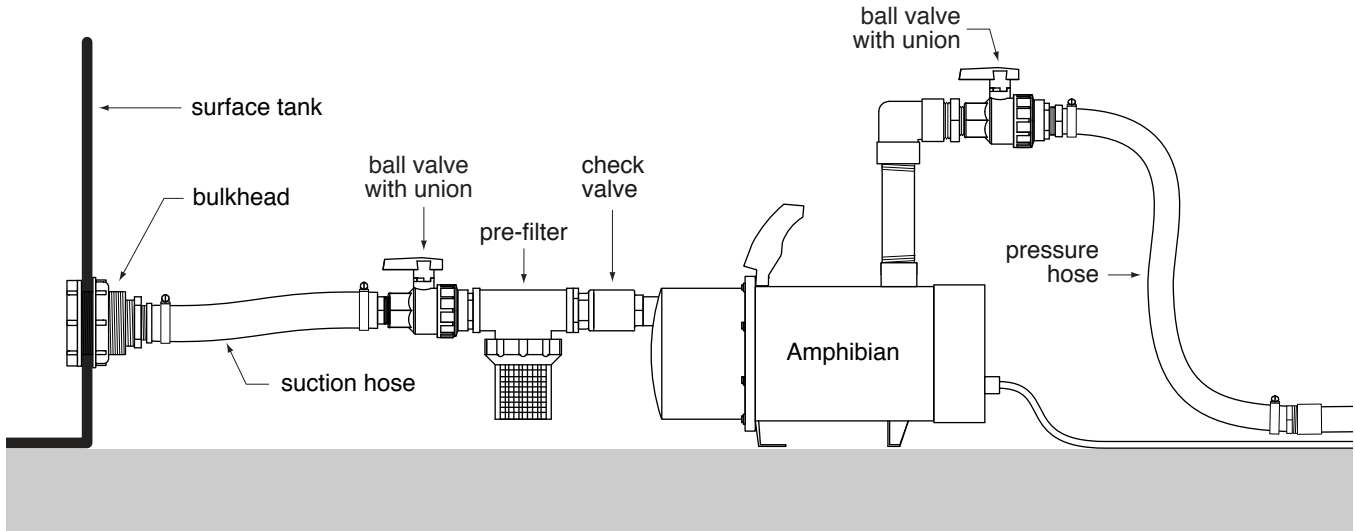

surface Amphibian system with screened pre-filter drawing water from surface tank

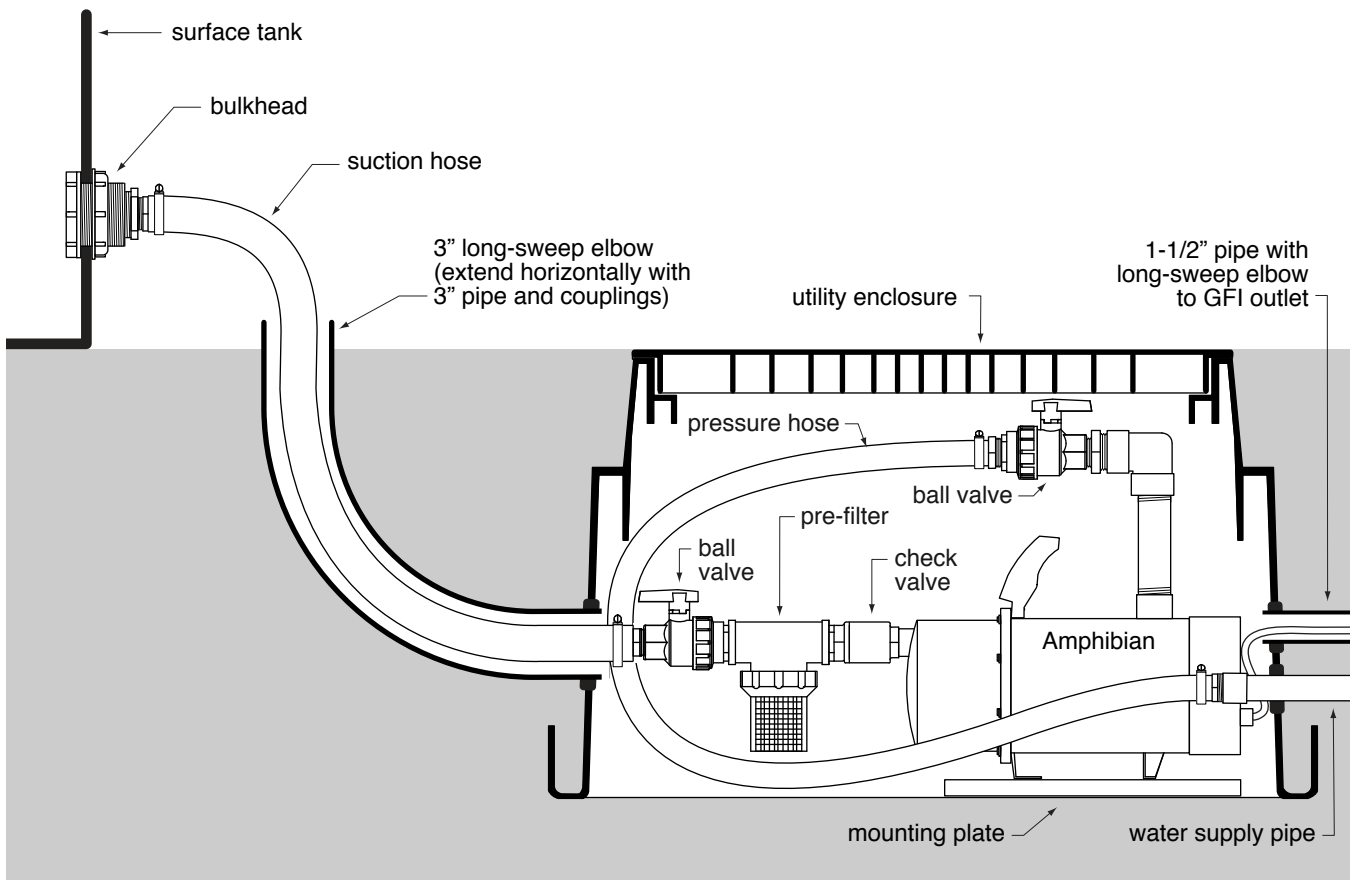

underground Amphibian system with screened pre-filter drawing water from surface tank

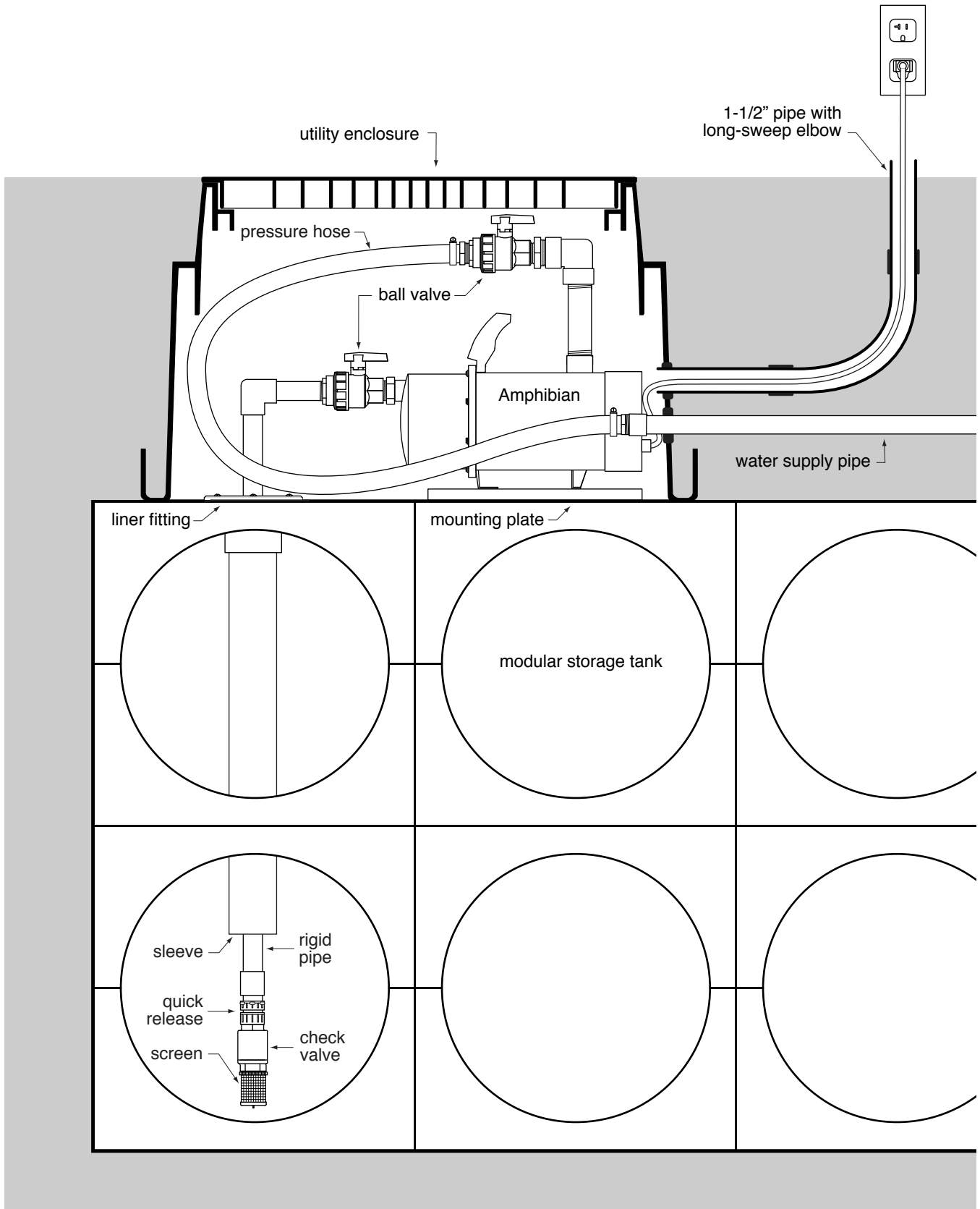

underground Amphibian system with screened pre-filter drawing water from underground tank